



Empire Series: Free Standing Single Door

A P P L I C A T I O N

- Designed to insulate and house electrical and electronic controls, instruments or components for indoor and outdoor applications
- Especially well suited for high temperature or corrosive environments
- Protects from dirt, dust, oil and water

S T A N D A R D S

- Construction meets NEMA/EEMAC Type 4, 4X specifications
- cUL 508 listed, Type 4, 4X

C O N S T R U C T I O N

- Durable, corrosion resistant fiberglass construction
- Soft, self-gripping gasket compresses over flange for tight seal and has one 3 point latching handle with padlocking provision
- Heavy-duty continuous 304 stainless steel hinge
- Fiberglass material has UV inhibitors which provide ideal protection from outdoor weathering
- Heavy duty lifting eyes
- Molded-in drip shield
- Fiberglass mounting strut installed on side and back wall

A C C E S S O R I E S

- Optional painted carbon steel back panels

M O D I F I C A T I O N S

See pages 74-78

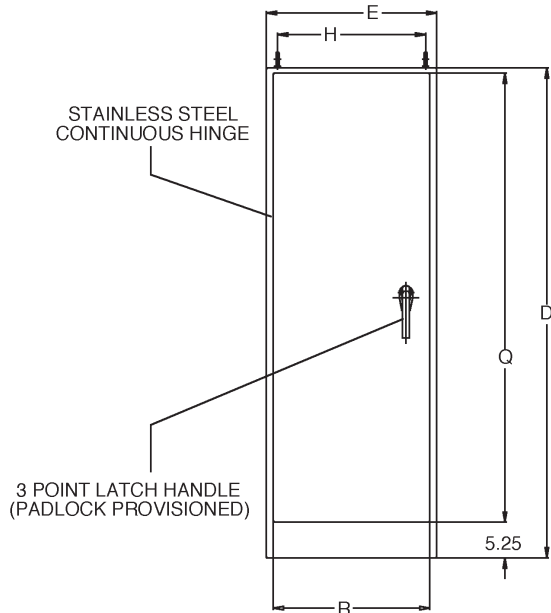

FRONT VIEW WITH DOOR

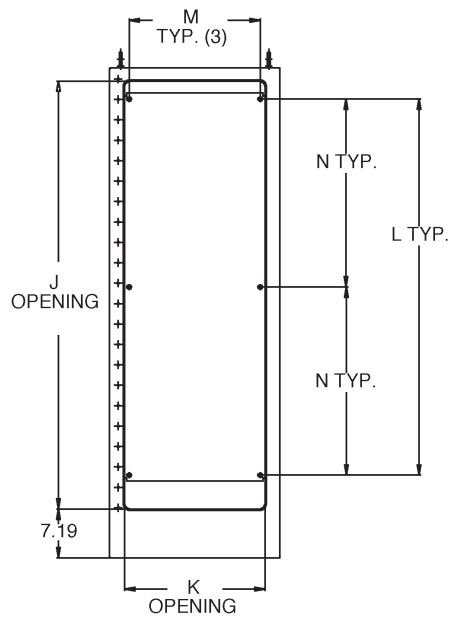

FRONT VIEW WITH DOOR REMOVED

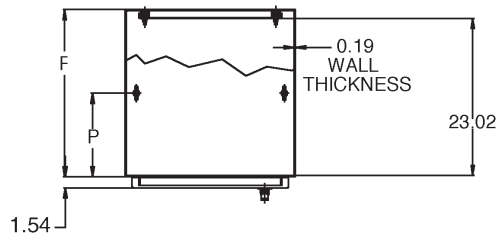

Part No.	D	E	F	H	J	K	L	M	N	P	Q	R	# PANEL MOUNT STUDS
AM722525FS	72.00	25.00	24.50	21.75	62.88	20.63	55.25	19.25	27.63	12.25	66.00	23.00	6

All dimensions in inches.

Optional Carbon Steel Back Panel		
Part No.	Height	Width
P7225CS	57.00	21.00