



Builder's Tools/ Woodworking

**Drill Accessories
Circle Cutters
Countersinks
Drill Bits
Gages
Layout Tools
Compasses
Calipers
Squares
Trammels
Scratch Awls
Moisture Meters**

Drill Accessories

General's Drill Accessories are engineered to do precision work in the many specialized drilling and cutting operations required for fine carpentry and metal working.

They expand the capabilities of portable electric drills, drill presses, drill stands, bit braces and hand drills. Our drill accessories are built for precision and durability.

WOODWORKING

PRECISION DRILL GUIDE

- Attaches to all 3/8" and 1/2" power drills.
- Cross slide lock for accurate shaping and carving.
- 3/8" capacity drill Chuck with key.
- Positive stop for accurate drill depth control.
- Dual locking knob and handle holds precise angle setting.
- Folds flat for tool box storage.
- Easy-to-read protractor scale has 5° graduations (0° - 45° left or right).
- V-guides automatically center round stock for drilling.
- Self centering channel for edge drilling.

UPC	NO.
23059 1	36/37 Complete set

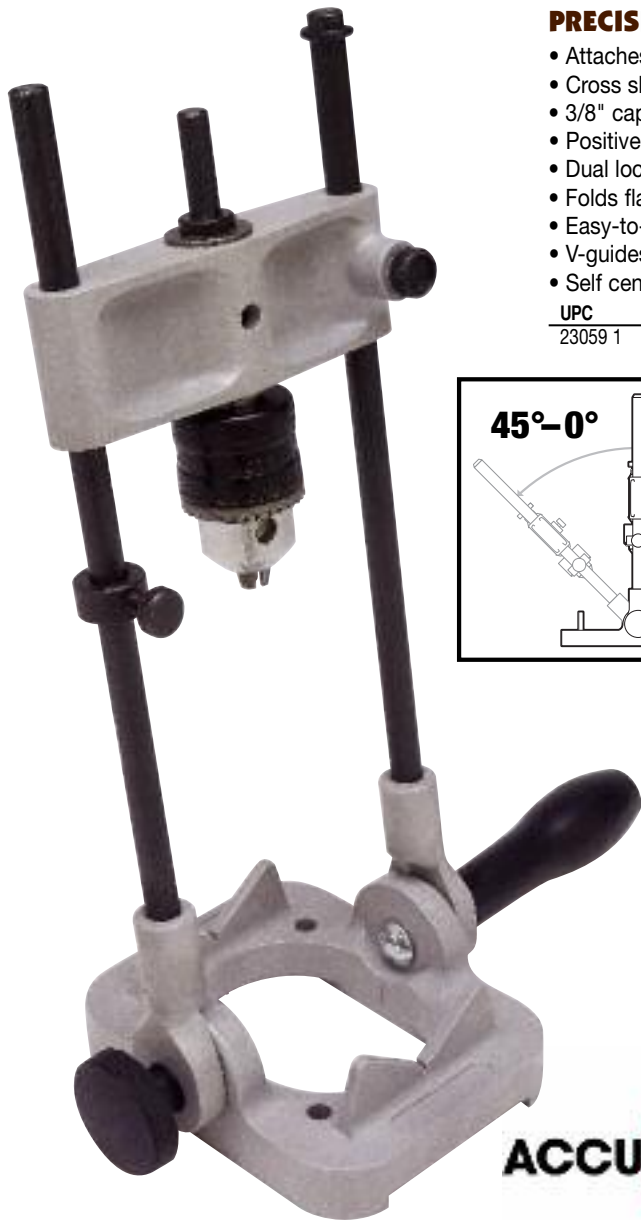

36/37

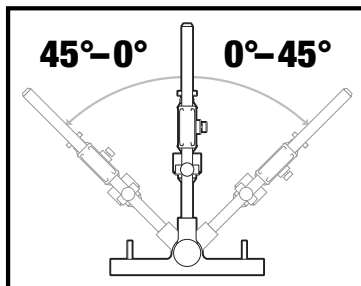

924

RIGHT ANGLE DRIVE

- Our Right Angle Drive reaches awkward corners and difficult angles easily; ideal for any close quarter drilling.
- Designed for use with portable electric drills, sanding or buffing attachments and other drill accessories.
- Plastic handle attaches for right or left-hand use.
- Designed for long life, the drive body is strong die-cast zinc, with permanently lubricated steel gears.
- 24-thread, 3/8" spindle has 3/8" drill chuck adapter.
- Chucks not included.

UPC	NO.
25115 2	924

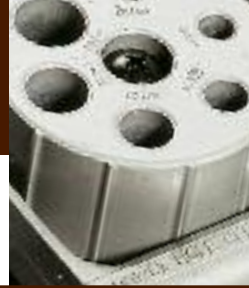

General's Doweling Jig is a precision jig that assures the accurate line-up of dowel holes in furniture and carpentry. Simply clamp the jig onto your workpiece to quickly and accurately drill holes for dowel pins

requiring exact alignment in the edge, end or surface of your work. General's Drill Grinding Attachment is engineered to permit the sharpening of drill bits to factory accuracy.

PRO DOWELING KIT

- A precision jig that assures accurate line up of dowel holes in furniture and carpentry.
- Revolving turret has six twist drill sizes.
- Just lift and turn turret to lock in guide hole.
- Black oxide guide bars are graduated for fast positioning of hole center points.
- Clamp screw locks tool onto work from 0" to 4" in width.
- Hardened sintered turret for durability. Painted to prevent rust.
- Package Contents: 1 Doweling Jig; 3 Brad Point Drill Bits, 1/4", 5/16", 3/8"; Dowel and Tenon Centers Set from 3/16" ID to 1/2" OD; 3 Drill Stops, 1/4", 5/16", 3/8"; 30 Dowel Pins, 10 Each 1/4", 5/16", 3/8"; Wood Glue.
- Instructions included.

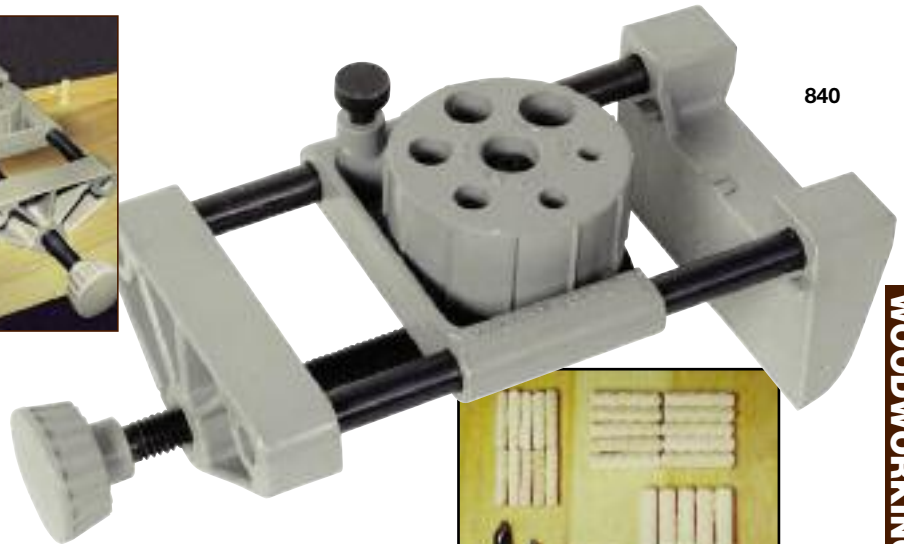

840

UPC	NO.	CAPACITY
24120 7	840	3/16", 1/4", 5/16", 3/8", 7/16", 1/2"

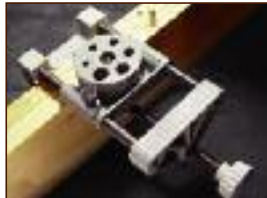
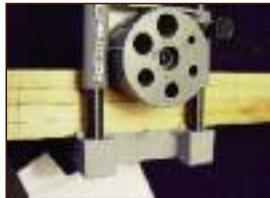

WOODWORKING

DOWEL PINS

- General's dowel centers are the quickest and most accurate method to locate, transfer and match dowel holes.
- Made of nickel plated steel.

- Set includes 8 pcs., two of each size: 1/4", 5/16", 3/8", 1/2" diameter.

UPC	NO.	
25099 5	888	Dowel centers



888

DRILL STOP SET

- For use on twist or brad point drills to prevent excessive drill penetration.
- Positive depth control assures exact hole depths for multiple drilling jobs.
- Black oxide finish on cold rolled steel.

- Includes hex wrench.

UPC	NO.	SIZES INCLUDED
23096 6	S838	3/16" dia., 1/4" dia., 5/16" dia., 3/8" dia., 7/16" dia., 1/2" dia.



S838

"ORIGINAL" DRILL GRINDING ATTACHMENT

- Engineered to permit sharpening of drill bits to factory accuracy.
- Extends the life of drill bits.
- Angle adjustments lock in to grind drill bits for more accurate drilling in a variety of materials.
- Automatically adjusts to give correct clearance angle.
- For use with ANSI, OSHA, and UL approved standard electric bench grinders or surface grinders.
- Equally at home in machine shop and home workshop.
- Instructions included.

UPC	NO.	CAPACITY
24070 5	825	Fractional drills 1/8" to 3/4", Number size drills 30 to 1 Letter size drills A to Z, Millimeter size drills 3.0 to 19.0



825

Cutting Guides

Pocket-Hole Joints are sturdy and simple to make with a driving jig. By drilling steeply pitched counter bores in one joint member, you can drive self-

tapping screws into the other without pilot holes. Ideal for leg and rail connections and cabinet construction.

E-Z™ POCKET HOLE JIG KIT

- Pocket hole joints are sturdy and simple to make with a drilling jig.
- By drilling steeply pitched counterbores in one joint member, you can drive self-tapping screws into the other without pilot holes.
- The joints are ideal for leg-and-rail connections, cabinet construction, sneaking screws into tight-squeeze spots or fastening picture frame miters.
- Heavy duty aluminum extrusion and hardened steel drill bushings.

- Built to be portable or bench mounted and designed with a clamping system built in.
- Kit includes: 1 Pocket Hole Jig with Clamps; 3/8" Step Drill Bit; 1 3/8" Drill Stop and Hex Wrench; 6" Steel Square Drive Bit; Square Drive Screws.

UPC	NO.
708200000515	849

WOODWORKING



849



Patent No. 6,254,320



Photos property of Woodworker's Journal

841

E-Z™ DOWEL KIT

- Dowels add mechanical strength to butt joints and keep miters lined up during clamping.
- The pointed notches on the working edges of our jig centers the drill bit automatically for precise registration.
- Indicate a thin layout mark across the joint where you want the dowel to be and registering the drill bit is easy.

- Create 3 types of dowel joints: Edge to edge, right angle, edge to surface, as well as 3 sizes of dowel joints; 1/4", 5/16" and 3/8".
- Ideal for 5/8", 3/4" and 1" thick stock.
- Kit includes: 1 Dowel Jig; 3 brad point drill bits; 1/4", 5/16", 3/8" and Hex Wrench, 3 steel stops 1/4", 5/16" and 3/8", 6 dowel center points; 2 each of 1/4", 5/16" 3/8", supply of wood dowels.

UPC	NO.
708200000317	841



Patent No. 7,001,118



Photos property of Woodworker's Journal



With General's Jointer Clamps you can straight line rip crooked boards on your table saw. Just mount the clamps to a guide board to create a flat

reference edge and then clamp the stock to the guide to make the rip cut. The alternative to expensive jointers.

E•Z™ JOINTER KIT

- Straight line rip crooked boards on your table saw.
- Just mount the clamps to a guide board to create a flat reference edge.
- The guide board can be made from any straight edged scrap.
- Cut a shallow rabbet along one edge to accept the clamp lips, as seen in figure 3.
- Clamp the stock to the guide board and make your rip cut.

- Get a dead-flat edge every time, with no extra waste.
- The jointer clamps work on any length stock up to 2" thick.
- The alternative to expensive jointers!

UPC	NO.	CAPACITY
708200000010	846	2" stock



846



Patent No. 7,000,519



New Swing Arm

Photos property of Woodworker's Journal

WOODWORKING



Holds stock in the proper position as shown in Figure 2.

E•Z™ LAMINATROL

848

- A laminate cutting guide for your table saw.
- Cut plastic laminates faster, truer and smoother.
- Works with any table saw.
- Holds stock in the proper position.
- Holds stock up to prevent jamming under the rip fence.
- Holds stock down to prevent stock from rising off the blade.

* Table saw shown without guard for demonstration purposes only! Always wear OSHA/ANSI approved eye protection when using tools.

UPC	NO.
708200000218	848



Figure 1



Figure 2

BUILDER'S TOOLS/WOODWORKING

Replacement/Accessories



General Tools now offers replacement and accessory parts for their new line of drill and wood joining jigs. The No. 32 replacement step drill bit is used with the No. 849 Pocket Hole Jig. No. 8401, Dowel Accessory

Kit, can be used for both the No. 840 and No. 841 doweling jigs. No's. 8497 and 8498 are pocket hold screws used specifically for pocket hole wood joinery. Offered in both fine and coarse thread.

WOODWORKING

32



E•Z™ STEP DRILL BIT

- Replacement bit for General's E•Z Pocket Hole Jig Kit (No. 849).
- 3/8" x 6" (9.5 x 152mm) step drill bit.
- High speed steel.
- Ideal for creating pocket hole joints and counter-boring.
- Includes 3/8" (9.5mm) steel drill stops with hex wrench.

UPC	NO.
70820000052 2	32



8401

E•Z™ DOWEL ACCESSORY KIT

- Replacement bit for General's E•Z Pocket Hole Jig Kit (No. 849).
- Accessories Kit for General's Pro Doweling Kit (No. 840) and E•Z Dowel Kit (No. 841).
- For 1/4", 5/16", 3/8".
- Kit includes
 - 3 Brad Point Drill Bits 1/4", 5/16", 3/8",
 - 6 Dowel and Tenon Centers from 3/16" ID to 1/2" OD,
 - 3 Drill Stops 1/4", 5/16", 3/8",
 - 30 Dowel Pins, 10 each 1/4", 5/16", 3/8" hex wrench.

UPC	NO.
08401 9	8401



8497

POCKET HOLE SCREWS

- Self-tapping.
- Use a coarse thread screw in soft material.
- Use a fine thread screw in hardwoods.
- Nickel-plated.
- Pan Head.
- Size: 1-1/4".

UPC	NO.	THREAD	COUNT/PKG
08497 2	8497	Coarse	100
08498 9	8498	Fine	100



No. 8497 shown actual size of 1-1/4"



General's circle cutters produce precision circles in sheet metal, brass, copper, soft steel, aluminum, plastic, wood and composition materials. Bodies are constructed of heat treated tool steel for durability.

The replaceable cutter blades are made of high-speed steel for precise and clean cuts. Circle Cutters are adjustable for cutting various diameter holes. A hex wrench is included for adjustments.

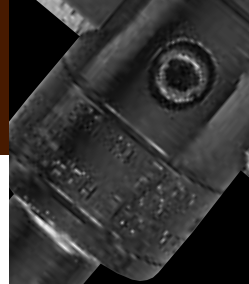

4" MAX CIRCLE CUTTER

- Round shank circle cutter for use with drill press or bit brace.
- Replaceable high-speed steel cutting blade and replaceable 1/4" pilot drill.
- Maximum safe speed is 500 RPM.
- All adjustments are made with a hex wrench which is included.
- **For use with drill press only.**

UPC	NO.	CAPACITY	SHANK
21003 6	04	7/8" to 4"	3/8" Round
27006 1	4 Drill		
27003 0	4/5 Blade		



04

WHEEL AND CIRCLE CUTTER

- General's Wheel and Circle Cutter is the only one that cuts the exact diameter you need anywhere from 1" to 6" (26 to 152mm).
- Ideal for woodworkers, model builders, clockmakers, and hobbyists.
- Produces precision circles and holes in sheet metal, brass, copper, aluminum, plastic, wood, and composition materials.
- Change from circle to wheel cutting by simply reversing the double ended blade.
- Sturdy round shank for use in any drill press or drill stand with 3/8" chuck.

- Maximum safe speed is 500 RPM.
- Replaceable double ended 9/32" cutter blade is made of high-speed steel for precise clean cuts.
- All adjustments are made with a hex wrench which is included.
- **For use with drill press only.**

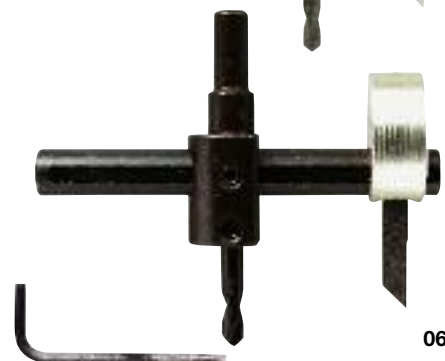
UPC	NO.	CAPACITY	SHANK
21010 4	06	1" to 6"	3/8" Round
21014 2	5/6/55 Drill		
21013 5	6 Blade		

06
WOODWORKING

6" MAX CIRCLE CUTTER

- Has been a General Tools customer favorite for more than 30 years.
- Adjusts from 1" to 6" (26 to 152mm) diameter circles.
- Replaceable high-speed steel blade and replaceable 1/4" pilot drill.
- Maximum safe speed is 500 RPM.
- All adjustments are made with a hex wrench which is included.
- **For use with drill press only.**

UPC	NO.	CAPACITY	SHANK
21009 8	5B	1" to 6"	3/8" Round
21014 2	5/6/55 Drill		
27003 0	4/5 Blade		

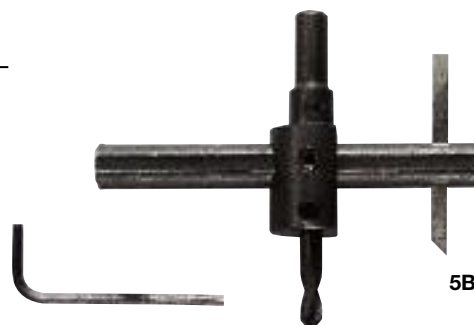
5B

HEAVY-DUTY CIRCLE CUTTER

- General's industrial quality cutter is most preferred by professionals.
- 1/2" round shank for drill press use.
- Replaceable high-speed tool steel blade and replaceable 1/4" pilot drill.
- Maximum safe speed is 500 RPM.
- Markings on beam for easy measurement.

- All adjustments are made with a hex wrench which is included.
- **For use with drill press only.**

UPC	NO.	CAPACITY	SHANK
21012 8	55	1-3/4" to 7-7/8"	1/2" Round
21014 2	5/6/55 Drill		
27015 3	55 Blade		

55

WASHER AND GASKET CUTTER

- This tool cuts washers and gaskets in leather, rubber, cork, graphite, fiber, copper and other soft materials.
- Combination round and square shank permits use with bit brace or hand drill.
- Made of steel with graduated beam to adjust to diameters from 5/8" to 6-1/2" (16 to 165mm).
- Replaceable tool steel Cutter Blades No. 11B.

- Two independently adjustable cutter blades cut inside and outside diameters simultaneously.
- **For bit brace and hand powered drill only.**

UPC	NO.	CAPACITY
21024 1	11	5/8" to 6-1/2"
27024 5	11B	Replacement blades (Pair)

11

BUILDER'S TOOLS/WOODWORKING

Countersinks & Drill Bits



Pilot Bits drill, countersink and counterbore precision screw holes in a single operation. Self-Centering Hinge Bits drill highly accurate pilot holes in cabinet and door hinges.

Plug Cutters cut plugs for covering screw holes for decking, flooring and other fine woodworking projects.

WOODWORKING

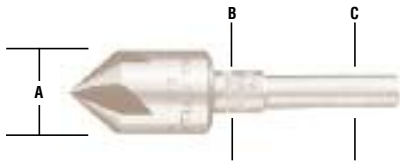

195-1/2



195-5/8



195-3/4

5 FLUTE ROSE PATTERN COUNTERSINKS

- The rose pattern cutting flutes assure chatter free countersinking on steel, brass, aluminum, plastic, wood & other materials.
- Made of high-speed steel with five flutes.
- 82° point angle.
- Stepped shank for use with 1/4" and 3/8" chucks.

UPC	NO.	A	B	C
23047 8	195-1/2	1/2"	3/8"	1/4"
23053 9	195-5/8	5/8"	3/8"	1/4"
23050 8	195-3/4	3/4"	3/8"	1/4"



810196

3/4" ULTRATECH COUNTERSINK

- Handy tool for countersinking or deburring small jobs.
- The 3/4" five-flute tool steel cutter makes fast work of deburring wood, plastic, copper, iron pipe and sheet metal.

- Precision engineered 800 Series Versa-Grip™ handle for maximum performance.
- Handle length - 4-1/2" (113mm), Blade length - 1" (25mm), OAL - 5-1/2" (140mm).

UPC	NO.	PKG.
81019 9	810196	Carded

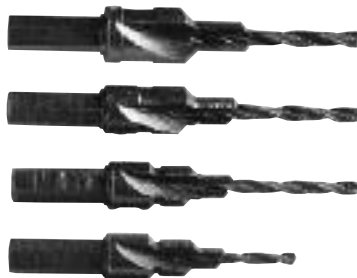

34ST

ADJUSTABLE PILOT BITS

- Drill, countersink and counterbore precision screw holes in a single operation when doing fine carpentry and woodworking.
- Hardened high-speed pilot bits give long life.
- Black oxide finish deters rust.

- 1/4" hex shanks prevents slippage in electric drills and can be used in power screwdrivers.
- Adjustable drill and high performance angle on countersink.

UPC	NO.	SCREW SIZES
23041 6	34ST	Set of 4 Pilot Bits (Sizes 5 - 14)



291



292



293

SELF-CENTERING HINGE BITS

- Highly accurate bits are used for drilling pilot holes in cabinet and door hinges, door butts and all large and small hardware.

- Spring loaded outer guide keeps the high speed drill centered for perfect pilot holes.
- Adjustable drill depth.

UPC	NO.	DRILL SIZE	DRILL DEPTH	SCREW SIZE
22154 4	291	5/64"	1/8"	3 & 4 screw size
22149 0	292	7/64"	7/32"	5 & 6 screw size
22150 6	293	9/64"	5/16"	8 & 10 screw size



31A



31B



31C

PLUG CUTTERS

- General's Plug Cutters produce accurate plugs for covering screw holes in decking, flooring and other woodworking projects.
- Permits choice of matching or contrasting plugs for decorative effect.
- Engineered to start cutting plugs easily with hand-held drills or drill press.
- Cutter will produce and eject straight plugs from stock up to 3/4" thickness.
- Made of hardened alloy steel.

- Individual sizes:

UPC	NO.	SHANK	DIA.
23024 9	31A	3/8"	3/8" dia.
23030 0	31B	3/8"	1/2" dia.
23033 1	31C	5/8"	5/8" dia.



General has a full range of gages designed for the specialized measurement operations necessary in construction jobs, cabinet making and fine

carpentry. Woodworkers trust the quality, accuracy and value that General Tools gives them. It's your job . . . General Tools make it easier.

JIFFY CENTERING PUNCH

- For quickly starting screw holes when attaching countersunk hardware such as hinges, hasps, hangers and drawer pulls.
- Countersunk end ensures starting hole is centered in hardware screw hole.

- Hardened steel pin.

UPC	NO.	LENGTH	BODY DIA.
24018 7	806	2-1/2" (68mm)	3/8" (10mm)



806

SAW BLADE DEPTH GAGE

- Heavy-duty, aluminum gage makes saw adjustments easy.
- Provides three separate scales: 1/8" (.125") increments up to 2-1/4" (2.25") with decimal equivalents, Metric from 3mm-18mm, 1/16" increments up to 3/8".

- Stamped graduations.

UPC	NO.	GRADS
22042 4	22	1/8" - 2-1/4" (3mm - 57mm) 1/16" - 3/8" (1.5mm - 9mm) 3mm - 18mm



22

WOODWORKING

HOBBY DRILL GAGE

- Heavy gage stainless steel gage conveniently identifies drill bit sizes.
- Etched graduations are filled in black to give high contrast and will not wear off.
- Gage measures 2-3/8" x 6-3/4" (60 x 172mm) overall.
- Stainless steel will not rust.

UPC	NO.	SPECIFICATIONS
22011 0	24	Fractional size drills 1/16" to 1/2" x 64ths



24

ROUTER GAGE

- Heavy-duty, aluminum gage makes router height adjustments easy.
- 1/16" (.062") increments up to 1-1/2" (1.50") with decimal equivalents.
- Stamped graduations.

UPC	NO.	SPECIFICATIONS
22046 2	23	1/16" - 1-1/2" (1.5mm - 38mm)



23

STAIR GAGE SET

- Brass plated steel stair gage assures fast and uniform layout in repetitive work including angle cuts on rafters and stair stringers.
- Attaches easily to all metal rafter squares.
- Set of 2 pieces.

UPC	NO.
24009 5	803



803

Layout Tools

General's Contour Gages can duplicate any shape. The stainless steel pins on our gage slide to conform to irregular surfaces. This tool can be used for pattern and mold making, duplicating parts and contours.

Great for fitting carpet, floor tiles and linoleum against door casings and pipes. The **ANGLE-IZER™** can replace the need for making templates and can be used again and again. **The Ultimate Template Tool.**

WOODWORKING



833



10" CONTOUR GAGE

- Extra length is ideal for woodworking, linoleum installation, ceramic tile installation or any job where contour duplication is essential.
- Gage will fit profiles up to 10" long.
- Inch/mm graduations on body.
- 3" (76mm) deep fingers will measure profiles up to 1-1/4" (32mm).
- Made from tough, durable plastic.

UPC	NO.
08330 2	833



837

6" CONTOUR GAGE

- Ideal for woodworking, linoleum installation, or any job or hobby where contour duplication is essential.
- Inch graduation on body.
- Stainless steel pins.
- Component parts are enamel painted and brass plated.
- Size is 6" x 3-1/2" (152 x 89mm) with an overall travel of 5-1/4" (133mm).

UPC	NO.
24116 0	837

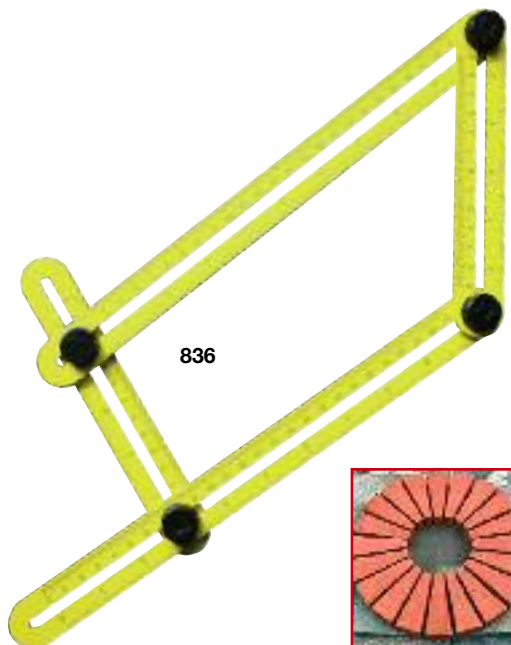

836

THE ANGLE-IZER™

- The unique and versatile **ANGLE-IZER™** The Ultimate Template Tool eliminates the need for making templates and can be used again and again.
- The **ANGLE-IZER™** can be set-up in seconds not only improving quality but saving time.
- Just form the tool into the shape of your work area, then use it to mark your work-piece to be cut.
- Repeat accurate marking for creating bulls eyes, arches, repetitive angles or shapes.

- Tool can be set to mark bricks, tiles, lumber and laminates.
- All the arms are dual-calibrated in inches and metric measures.
- Unique tightening mechanism for one-handed operations.
- Fiberglass filled nylon for added strength and flexibility.
- Includes FREE instructional **ANGLE-IZER™** CD program.

UPC	NO.
08360 9	836



REPETITIVE MARKING



MARKING LUMBER



ANGLES FOR PAVER BRICKS



TILING



SPACING AND GAUGING



BUILDER'S TOOLS/WOODWORKING

Layout Tools



General's compasses and layout tools are designed for the specialized operations of measuring and layout necessary in construction

jobs, cabinet-making and fine carpentry. Woodworkers trust the quality and the value that General Tools provides.

OUTSIDE, INSIDE & SLOPED ANGLE PROTRACTOR

- Use this protractor/angle finder to measure and mark the degrees of an angle on outside, inside and sloped angles.
- Fine black graduations from 0° to 165° in opposite directions.
- Brass lock nut.

UPC	NO.
22148 3	29

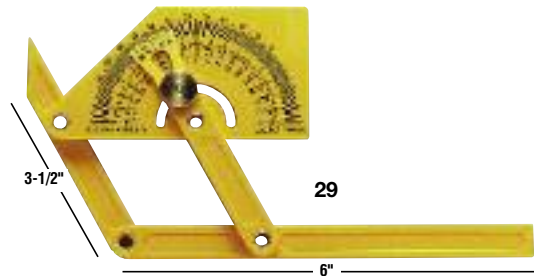

PROFESSIONAL QUALITY T-BEVEL

- Our T-bevel is the tool preferred by the craftsman who wants the finest.
- Solid mahogany 5-1/2" (140mm) handle with brass trim and locking wing nut.
- 8" (203mm) blade.
- Conforms to government specifications GGG-B-211b.

UPC	NO.
24100 9	829



FIBERGLASS FOLDING RULE

- Constructed of tough, flexible high impact plastic, with fiberglass reinforcement for added durability.
- 72" (1929mm) folding ruler with a 6" (152mm) extension for accurate inside measurements.

UPC	NO.	GRADS
25300 2	7200	Outside readings 16ths graduated in 16ths.



PENCIL COMPASS AND SCRIBER

- Designed for marking contours and circles.
- Positive wingnut adjustment.
- Full-length hardened steel pin in metal frame for greater rigidity.
- Constructed of brass plated steel.

UPC	NO.	CAPACITY
24132 0	843/1	8" (203mm)



PRECISION PENCIL COMPASS

- Carpenter quality compass is made of long lasting die-cast, rust resistant metal.
- Spring tension adjustment for marking up to 9" (229mm) diameters.
- Scribe guide for edge marking.
- For use with pencil (included) or slim ballpoint pen.

UPC	NO.	CAPACITY
24126 9	842	9" (229mm)

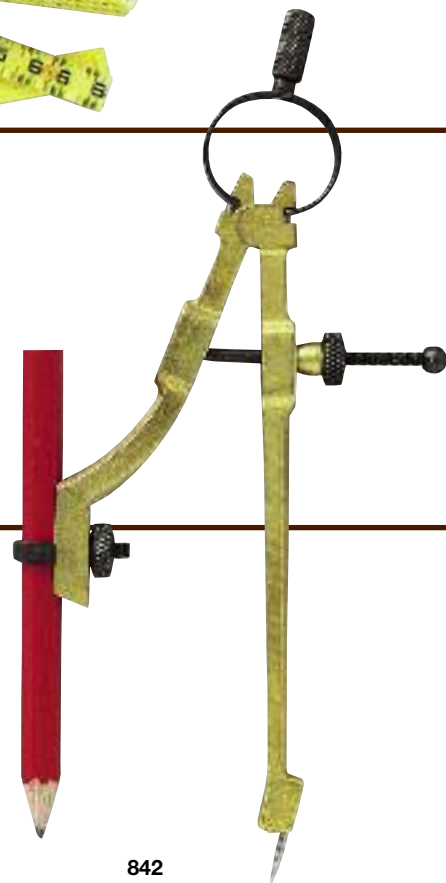

WOODWORKING

Caliper & Squares

General's newest "Fraction +" caliper has a 3 mode digital display. Measuring in inches, metric and fractions it offers everything for the hobbyist to the professional.

The combination squares are specifically designed for carpenters, the woodworking trade, the do-it-yourselfer and home mechanics. A necessary tool for every carpenter and home workshop.



147



No. 146 Digital Display



No. 147 Fractional Display

FRACTION+

DIGITAL FRACTIONAL CALIPERS

- No. 147, No. 1478, No. 14712 are Heavy Duty Stainless Steel Construction.
- No. 146 has a Non-Marring Plastic Housing.
- Convenient Auto On/Off Feature.
- Three Mode Digital Display: Decimal Inches, Fractions, Metric.
- Accuracy: +/- 0.001" +/- 0.02mm.
- Resolution: 0.0005", 0.01mm, 1/64".
- Includes: 1 "LR44/357" battery

UPC	NO.	RANGE
01460 3	146	0 - 6" (0 - 153mm)
01470 2	147	0 - 6" (0 - 153mm)
01478 3	1478	0 - 8" (0 - 203mm)
14712 7	14712	0 - 12" (0 - 305mm)

WOODWORKING



820

SINGLE BAR MARKING GAGE

- 6" (153mm) adjustable bar is nickel plated steel graduated in 16ths.
- Die-cast head.
- Fine needle point for precision marking.

UPC	NO.
24050 7	820

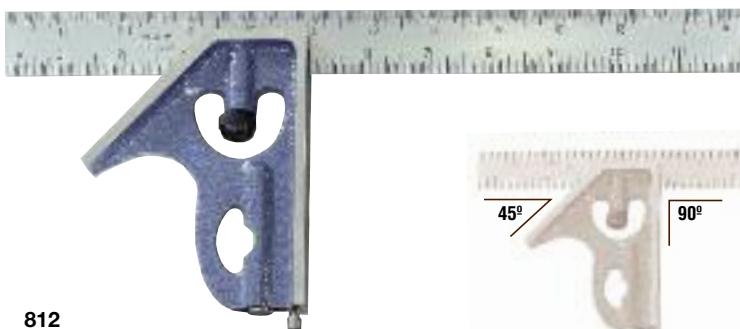

812

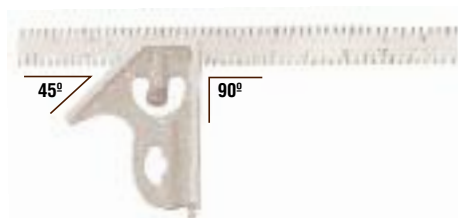

PROFESSIONAL CARPENTER'S COMBINATION SQUARE

- Specially designed for carpenters and the woodworking trades.
- Machined and enameled cast iron head has precision level and scriber for producing right and 45° angles.
- 12" x 1" (305 x 26mm) steel blade is graduated in 8ths, 16ths, and 32nds.
- Conforms to government specifications GGG-S-656C.

UPC	NO.	GRADS	
		FRONT	BACK
24036 1	812	8ths, 16ths	16ths, 32nds
22193 3	812-CA	Clamp Assembly	

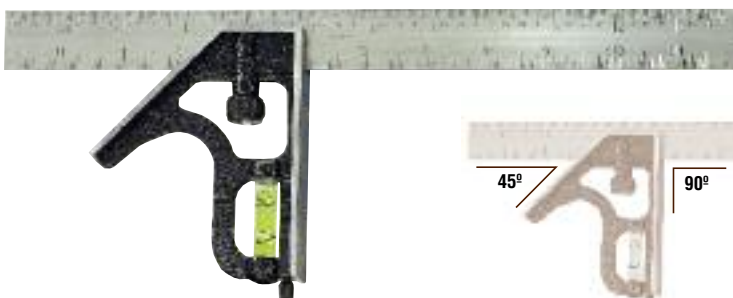

811



UTILITY COMBINATION SQUARE

- Economy version of the carpenter's combination square is perfect for the do-it-yourselfer and home mechanic.
- 12" x 1" (305 x 26mm) steel blade is graduated in 8ths, 16ths, and 32nds.
- Heavy zinc cast head with level and scriber.

UPC	NO.	GRADS	
		FRONT	BACK
24030 9	811	8ths, 16ths	16ths, 32nds

General's adjustable trammels accurately measure and mark distances that are too great for conventional compasses and dividers. Trammels will accurately transfer measurements, scribe arcs

and lay out circles. Points can be replaced with pencils, ballpoint pens, crayons or soap-stone sticks for marking various materials.

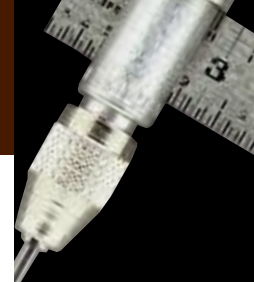

PRECISION ADJUSTABLE TRAMMELS

- Draw large circles and measure sizable distances with the accuracy of a divider.
- Fine adjusting screw sets points accurately.
- Points are removable and may be replaced with the pencil holder.
- Die-cast bodies with hardened and ground 3" (76mm) needlepoint legs.
- Clamp opening for beam is 3/8" x 3/4" (10 x 19mm).
- Conform to government specifications GGG-T-661b.

UPC	NO.
23090 4	520
31104 7	84P Replacement points (12 per pkg.)

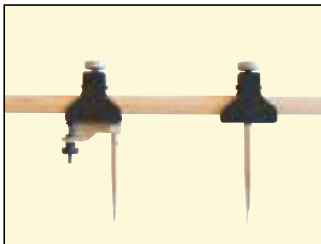

PROFILE VIEW

520

WOODWORKING

ADJUSTABLE TRAMMELS

- General's adjustable trammels accurately measure and mark distances that are too great for conventional compasses and dividers.
- For layouts, marking templates, and drawing large circles.
- 6" (153mm) off-center eccentric points provide fine adjustments.
- Points can be replaced with pencils, ballpoint pens, crayons, or soapstone sticks for marking various materials.
- Clamps onto beam 5/8" to 1-1/2" (16 to 38mm) thick of any length.

UPC	NO.
23093 5	523

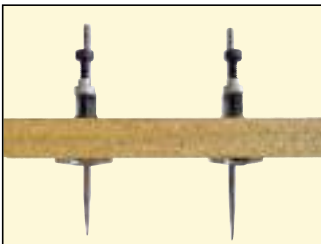

PROFILE VIEW

523

PRECISION TRAMMEL SET

- Will accurately transfer measurements, scribe arcs, and lay out circles too large for conventional compasses.
- Will fit any scale, 1/2" to 1-1/8" (13 to 29mm) wide.
- Two scriber points and two pencil points included.
- Up to four points can be stored in body.
- Free-wheeling thimble for greater precision.
- Aluminum knurled body.
- Steel collet holds replacement leads, scribes and crayons.
- Points reverse into body for safety.
- Ruler not included in set.

UPC	NO.
23095 9	524



PROFILE VIEW

524

Scratch Awls

General's scratch awls are made from the finest materials for long life. These tools are designed for scribing and layout work, starting screw holes and piercing soft materials.

The Chisel/Plane Blade Sharpener keeps blades razor sharp. The graduated settings maintain the correct 30° cutting angle necessary for these blades.

WOODWORKING

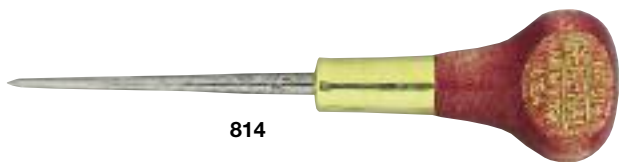

814



818



817

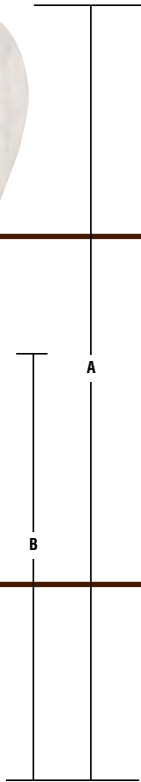

FLAT HANDLE SCRATCH AWL

- General Tools' finest quality scratch awl meets government specifications GGG-A-891a.
- 3-1/2" (89mm) alloy steel blade runs through the handle.
- Plated steel ferrule.

UPC	NO.	A	B
24039 2	814	6-1/4" (159mm)	3-1/2" (89mm)

HARDWOOD HANDLE SCRATCH AWL

- Alloy steel blade runs through the handle and is securely fastened to both the plated steel ferrule and the cap.
- Hardwood fluted handle is contoured for comfortable grip.
- Our finest best selling scratch awl.

UPC	NO.	A	B
24047 7	818	6-1/2" (165mm)	3-3/4" (95mm)

SCREWDRIVER HANDLE SCRATCH AWL

- Blade is firmly attached to durable plastic handle.

UPC	NO.	A	B
24044 6	817	5-3/4" (146mm)	3-5/8" (92mm)

ULTRATECH™ FULL SIZE AWL

810817

- Alloy steel blade runs through the handle and is securely fastened to the cap.



- Designed for scribing and layout work, starting screw holes and piercing soft materials.
- Precision engineered 800 Series Versa-Grip™ handle for maximum performance.
- Handle length - 4-1/2" (113mm), Blade length - 4" (102mm), OAL - 8-1/2" (216mm).

UPC	NO.	PKG.
81018 2	810817	Carded



809

CHISEL/PLANE BLADE SHARPENER

- Keeps chisel and plane blades razor sharp.
- Graduated settings maintain correct 30° cutting angle on chisel or plane blade.

- Spring clamp locks in blades up to 2-5/8" (67mm) wide.
- Made of high impact fiberglass reinforced Lexan®.
- Folds for storage.

UPC	NO.
24024 8	809

FEATURES

SPECIFICATIONS

MOISTURE METER

Ideal to use in woodworking, building construction and agriculture. Meter is also used in the restoration business to check if there is moisture in carpets and sub-flooring.

- LED Display
- Check wood, drywall and concrete before painting, sealing or treating
- Locate and identify water leaks in roofs, floors & walls
- Ideal for selecting dry lumber
- Great for home owners, contractors and inspectors

- ◆ Display: Progressive LED's, 3 Green (5, 10, 12%); 2 yellow (14, 16%); 3 Red (18, 20, 22%)
- ◆ Range: 8-22%
- ◆ Resolution: 0.1%
- ◆ Accuracy: ±2%
- ◆ Sampling Rate: 1s
- ◆ Operating Environment: 32° to 122°F (0 to 50°C), RH<90%
- ◆ Size: 5.7" x 2.4" x 1.2" (145 x 60 x 30mm)
- ◆ Weight: 4.4oz (125g)
- Includes: • Protective Cover

UPC	NO.
10188 9	MM1E



MM1E

DIGITAL MOISTURE METER

Ideal to use in woodworking, building construction and agriculture. Meter is also used in the restoration business to check if there is moisture in carpets and sub-flooring.

- LCD display.
- Wide measuring range.
- Check wood, drywall and concrete before painting, sealing or treating.
- Locate and identify water leaks in roofs, floors & walls.
- Great for home owners, contractors and inspectors.
- Display will directly show the moisture content in "% moisture Content".
- Built-in low battery indicator.

- ◆ Display: 3 digit, 10mm LCD
- ◆ Range: 8-30%
- ◆ Resolution: 0.1%
- ◆ Accuracy: ±2%
- ◆ Sampling Rate: 1s
- ◆ Operating Environment: 32° to 122°F (0° to 50°C), RH<90%
- ◆ Size: 5.7" x 2.4" x 1.2" (145 x 60 x 30mm)
- ◆ Weight: 4.4oz (125g)
- Includes: • Protective Cover

UPC	NO.
41447 7	MMD4E



MMD4E

NON-INVASIVE MOISTURE METER

Ideal for use in wood / timber industry and building material storage.

- Moisture display on LCD.
- Data hold to freeze reading and display.
- Auto calibration.
- Low battery indication.
- Sense 6 different materials including 50 types of wood/timber.
- Audible sound at 'peak' detection.
- Auto power off.

- ◆ Measuring moisture from 0.0% to 99.9% with 10 different groups
- ◆ Resolution: ±1 digit
- ◆ Sense depth maximum: 3/4" (20mm)

UPC	NO.
40142 2	MMD5NP



MMD5NP

PRECISION DIGITAL & LED MOISTURE METER

Measures moisture content in wood, timber and other commercial / industrial material.

- Wood and Concrete moisture measurement.
- Wood material: 6% TO 40% moisture content.
- Concrete material: 0% to 100% moisture content.
- Red LED bar graph indicator with LCD display.
- Easy Operation.
- Replaceable Tips.
- Hold, Record (Min/Max).

Includes: • 4 "AAA" batteries

UPC	NO.
07003 1	MMD7003



MMD7003



FEATURES

SPECIFICATIONS

MMD6NP



NON-INVASIVE MOISTURE METER

Precision instrument for highly sensitive and non-invasive measurement of moisture content in wood, timber and other industrial applications.

- High accuracy.
- Fast measuring time.
- Wide measuring range and high resolution.
- High resolution digital display.
- Zero value and correction value can be stored.
- Strong, light weight ABS-plastic housing.
- Comfortable fit for either hand.

- ◆ Display: 3 digits, 10mm LCD
- ◆ Range: 0 to 80% ◆ Resolution: 0.1%
- ◆ Accuracy: $\pm(1\%n+1)$ under 30%,
 $\pm(2\%n+1)$ over 30%
- ◆ Sampling time: 1.0s
- ◆ Operating condition:
Temp. 0° to 50°C, Humidity: <80%
- ◆ Dimensions: 218 x 76 x 53mm
- ◆ Weight: 260g (with batteries)
- Includes: • 4 "AAA" batteries • Carrying Case

UPC	NO.
40143 9	MMD6NP

WOODWORKING

329



MOISTURE TEST METER

- Test hard or soft wood, concrete, plaster, carpet and more to determine the extent of moisture problems.
- Find out if potentially damaging excess moisture is present.
- Locate and trace roof leaks and water seepage and assess the extent of wet rot and hidden condensation.
- Use it to check surfaces before painting, wallpapering or laying floors or tile.

- Helps you select drier lumber.
- Contact probes are on a 3 foot coiled cable for testing in hard to reach spots.
- Dual reading scale gives relative (1-10) and moisture percentage (10-28%) readings.
- Great for inspectors, contractors and homeowners.
- Requires one 9 volt battery (not included).

UPC	NO.
03290 4	329

MM70

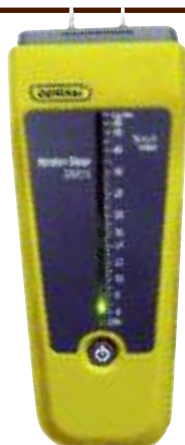

For additional information, see page 148

PRECISION LED MOISTURE METER

Precision instrument for accurate moisture reading in wood and timber.

- High Resolution Multi-color LED Bargraph readout 5.5% to 99.9% moisture range, with 0 to 1VDC output protective cap for safe carrying and operation.
- Auto temperature compensation and calibration adjustment.
- Auto power off.
- CE and RoHS approved.
- Auto Power Off.
- Changeable Probes.
- Easy operation.
- Audible Alarm starts for catch reading.
- Audible and visual low battery warning.

- ◆ Measuring Range: 5.5 to 99.9% H₂O %WME
- ◆ Accuracy (at 25°C): $\pm 1\%$ Wood Scale
- ◆ Indicator: LED bargraph
- ◆ Color Codes: Green (<16%)
Yellow / Red (>21%)
- ◆ Signal Output: 0 to 1Vdc 10mV%
- ◆ Calibration: Automatic Temperature compensation
- ◆ Built-in calibration adjustment
- Includes: • 1 "9V" battery

UPC	NO.
07020 8	MM70

MM70D



For additional information, see page 148

PRECISION DIGITAL MOISTURE METER °F/°C W/ RS232 OUTPUT

Precision digital instrument for accurate moisture reading in wood and timber.

- Digital LCD display with luminescent back-light.
- Protective cap for safe carrying and operation.
- Hardened and gloss treatment on display-window for long-term clean lens.
- Auto temperature compensation and internal calibration.
- Auto power off.
- CE and RoHS approved.
- Back-Light luminescence LED.
- Data-Hold, Records Min/Max and Average values.
- Battery symbol and audible low power warning.
- Usable and changeable extension probe.

- ◆ Measuring Range: 5.5 ~ 99.9% H₂O %WME
- ◆ Resolution: 0.1%
- ◆ Accuracy: (at 25°C) $\pm 1\%$ Wood scale
- ◆ Display: Digital dual LCD display, with multi-function indicator
- ◆ Sampling Rate: 0.3 seconds
- ◆ Wood group scales: Select from 8 wood species groups
- ◆ Data memory: 99 readings
- ◆ Signal output: Analog DC 0 ~ 1V
(10 mV / 1%), load > 500Ω
- ◆ Calibration: Built-in calibration adjustment
- Includes: • 1 "9V" battery

UPC	NO.
07010 9	MM70D