

Control Circuit Schematics

Figure 1 Three Wire Control Giving Low Voltage Protection Using Single Two Button Station

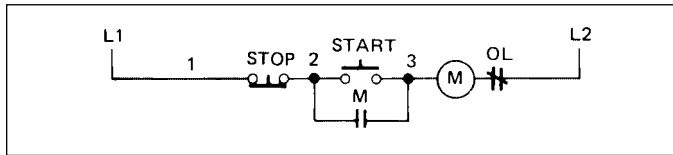

Figure 2 Three Wire Control Giving Low Voltage Protection Using Multiple Two Button Stations

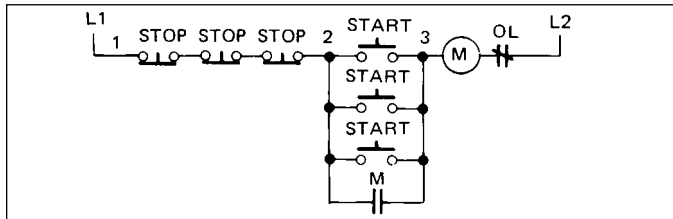

Figure 3 Three Wire Control Giving Low Voltage Protection with Safe-Run Selector Switch

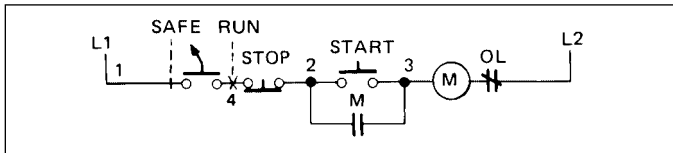

Figure 4 Three Wire Control for Jog or Run Using Start Stop Push Buttons and Jog-Run Selector Switch

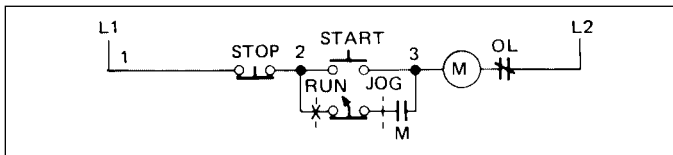

Figure 5 Control for Jog or Run Using Stop Push Button and Jog-Run Selector Push Selector Switch. Selector Push Contacts are Shown for "Run" (Three Wire Operation). Rotate Switch Sleeve and Selector Contact Opens Between "2" and "Stop" Button (Two Wire Operation)

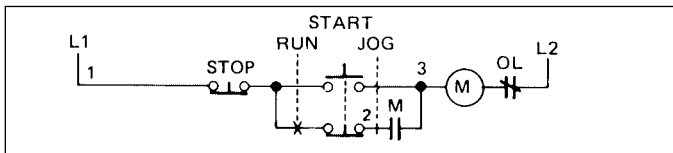

Figure 6 Three Wire Control for Jogging, Start, Stop Using Push Buttons

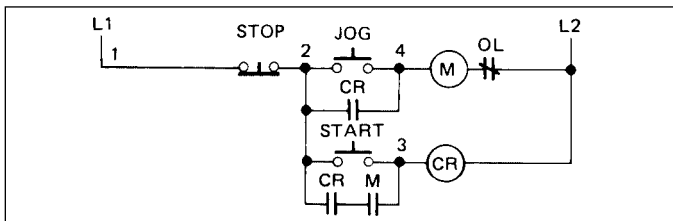

Figure 7 Two Wire Control Giving Low Voltage Release Only Using Hand-Off-Auto Selector Switch

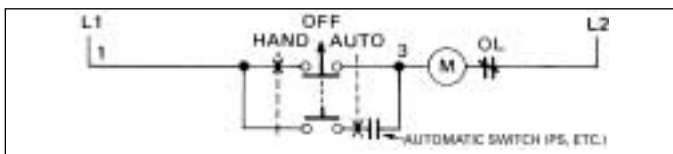

Figure 8 Two Wire Control for Reversing Jogging Using Single Two Button Station

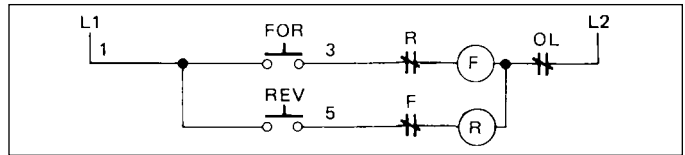

Figure 9 Three Wire Control for Instant Reversing Applications Using Single Three Button Station

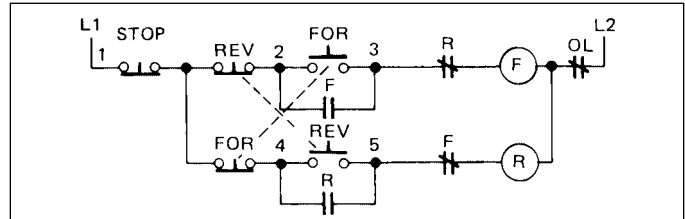

Figure 10 Three Wire Control for Reversing After Stop Using Single Three Button Station

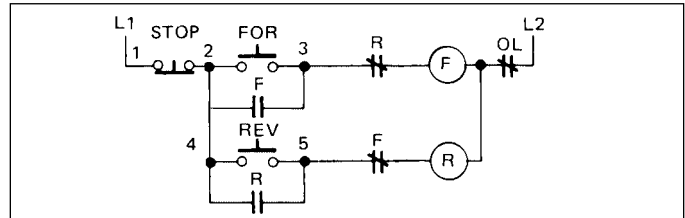

Figure 11 Control for Three Speed with Selective Circuitry to Insure the Stop Button is Pressed Before Going to a Lower Speed

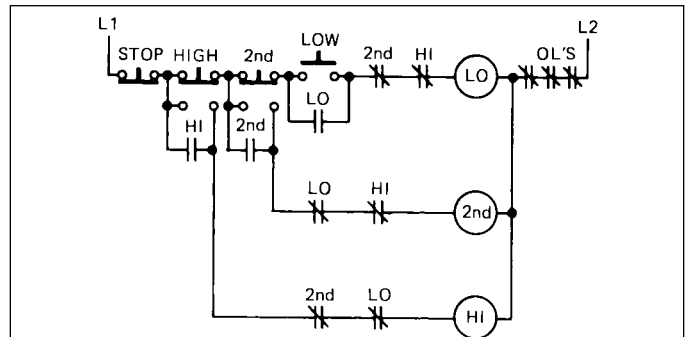
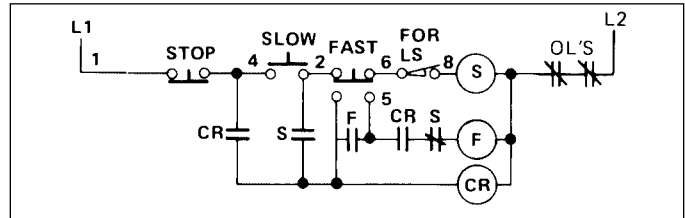

Figure 12 Three Wire Control for Two Speed with a Compelling Relay to Insure Starting on Slow Speed



Control Circuit Schematics and Wiring Diagrams with Transformers

Figure 13 Control for Three Speed with a Compelling Relay to Insure Starting on Low Speed

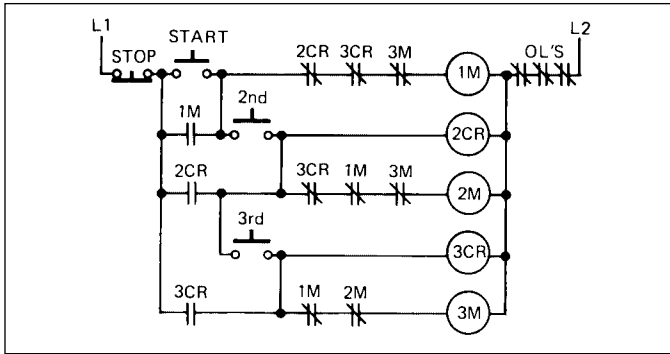

Figure 14 Control for Two Speed to Provide Automatic Acceleration from Low to High Speed

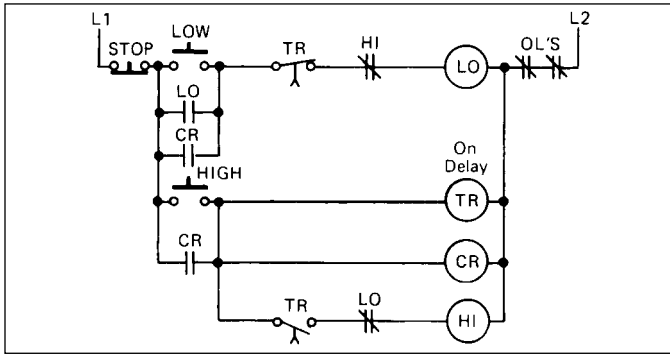

Figure 15 Control for Two Speed to Provide Automatic Deceleration from High to Low Speed

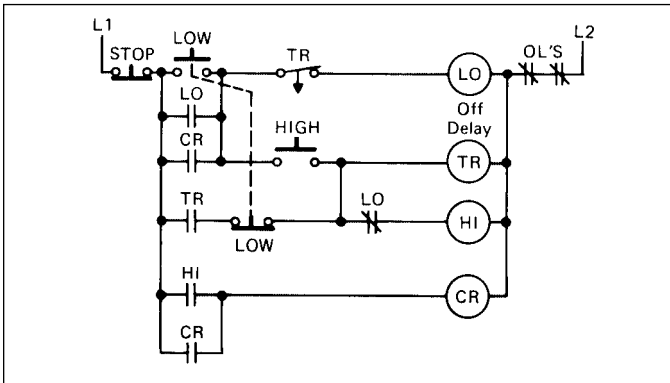
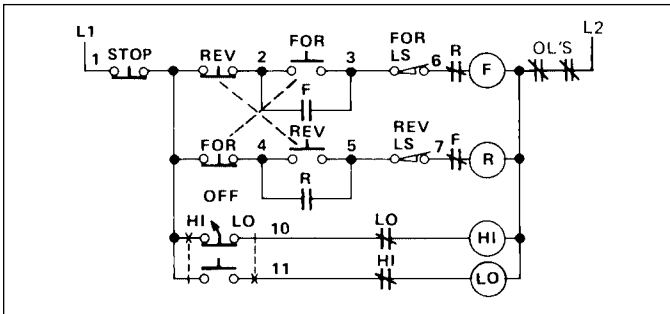
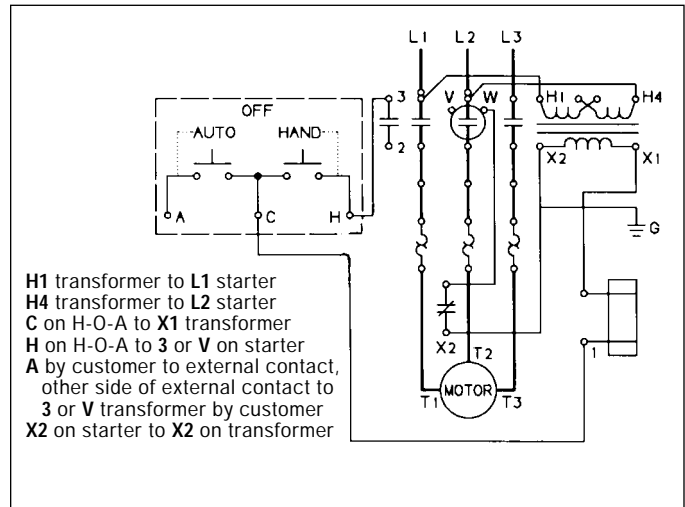

Figure 16 Control for Two Speed Reversing Starter Using Forward, Reverse, Stop Push Buttons and High-Low-Off Selector Switch



Size 0-2½ Starter with Transformer and 3 Position Selector Switch



H1 transformer to L1 starter
 H4 transformer to L2 starter
 C on H-O-A to X1 transformer
 H on H-O-A to 3 or V on starter
 A by customer to external contact,
 other side of external contact to
 3 or V transformer by customer
 X2 on starter to X2 on transformer

1
 Application
 Data

Size 0-2½ Starter with Transformer and 2 Position Selector Switch

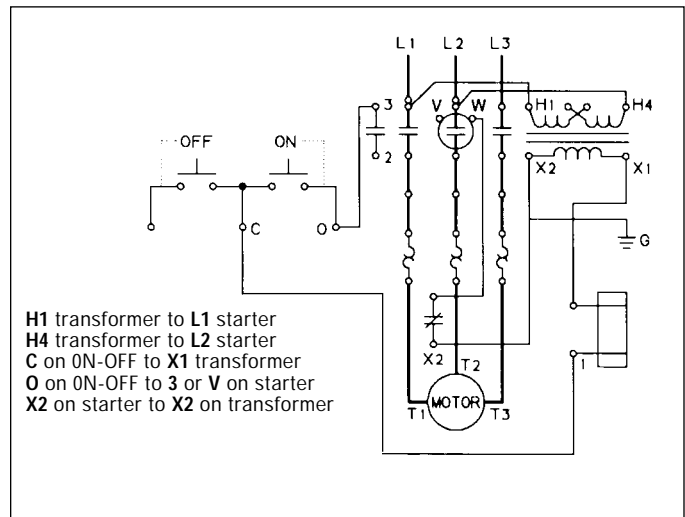

H1 transformer to L1 starter
 H4 transformer to L2 starter
 C on ON-OFF to X1 transformer
 O on ON-OFF to 3 or V on starter
 X2 on starter to X2 on transformer

Size 0-2½ Starter with Transformer and START-STOP Push Button

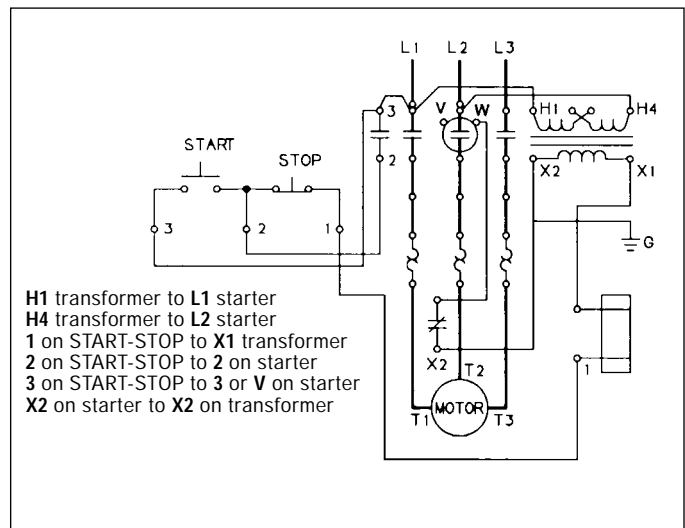

H1 transformer to L1 starter
 H4 transformer to L2 starter
 1 on START-STOP to X1 transformer
 2 on START-STOP to 2 on starter
 3 on START-STOP to 3 or V on starter
 X2 on starter to X2 on transformer