

## Pilot Control

Application Data

1

### AC Coil—NEMA Size 0–4

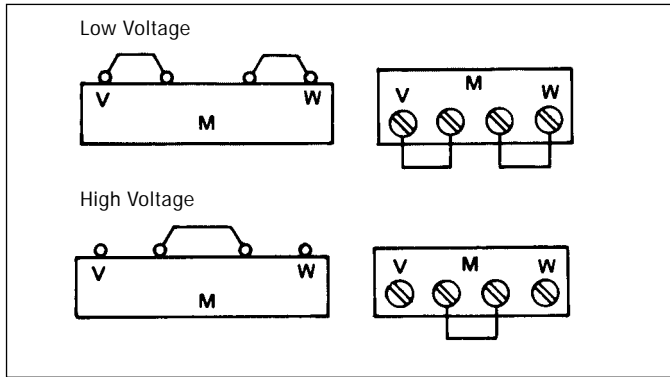

### DC Coil—NEMA Size 0–4

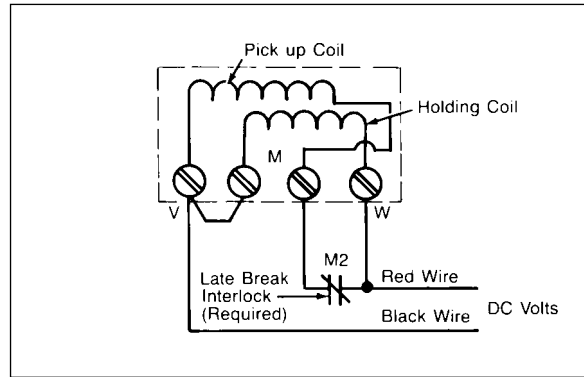

**Non Reversing Pilot Control** Terminal Markings shown in ( ) indicate IEC Style. For separate control voltage source remove Jumper A shown individual in wiring diagrams. Connect separate voltage source to terminal 1 on the pilot device as shown and to the terminal X2 on the overload relay, or W(A2) on the coil if there is no overload.

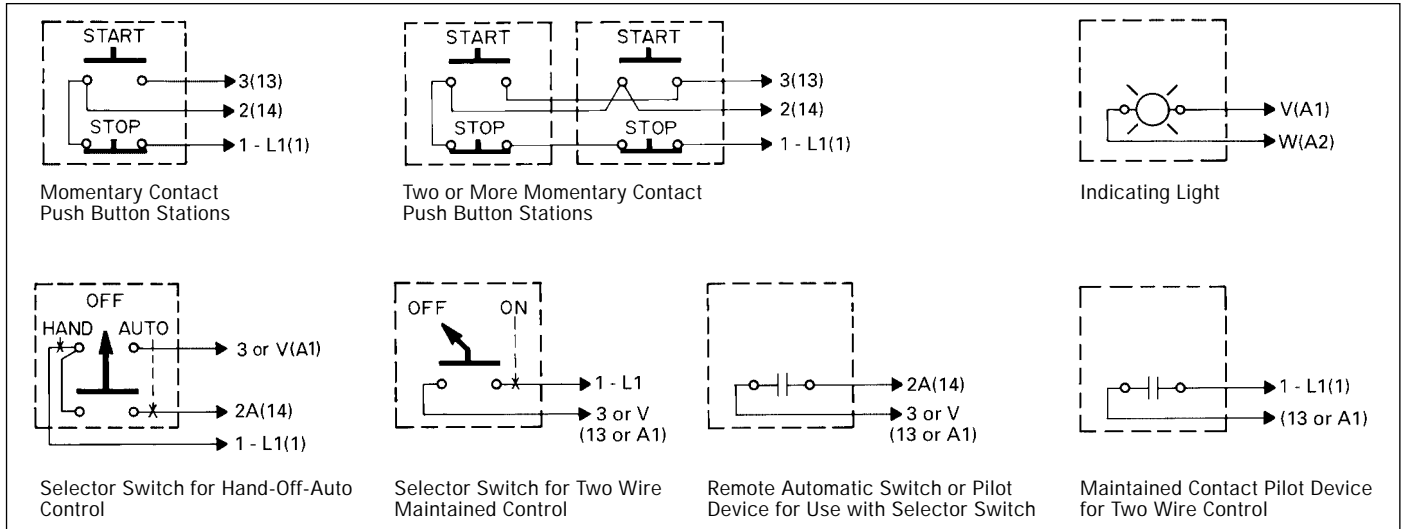

**Reversing Pilot Control** For Separate control voltage source remove Jumper A shown in individual wiring diagrams. Connect separate voltage source to terminal 1 on the pilot device as shown and to the terminal X2 on the overload relay, or W(A2) on the coil if there is no overload.

